

## 2026 SLMR Series Rules

REVISED 03/12/2026

REVISED 04/13/2026



SLMR SERIES  
I-80 Promotions Inc.  
5040 I St  
Omaha, NE 68117  
[www.slmrseries.com](http://www.slmrseries.com)

OFFICE CONTACT- Phone: 402-342-3453, Email: [office@i-80speedway.com](mailto:office@i-80speedway.com)  
TECH QUESTIONS- RICK - Phone: 402-515-1635, Email: [ricotech92@cox.net](mailto:ricotech92@cox.net)  
TIM - Phone: 402-639-3126, Email: [timjohnhansen@gmail.com](mailto:timjohnhansen@gmail.com)

## Table of Contents

- Section 1 – Engines
- Section 2 – Transmission, Driveline and Driveline Components
- Section 3 – Fuel, Fuel Cells, and Fuel System
- Section 4 – Electrical Systems, Batteries, Electrical Accessories
- Section 5 – Exhaust, Muffler, and Sound Reduction Devices
- Section 6 – Ignition Boxes, Traction Control, Radio & Transmission Devices
- Section 7 – Chassis and Frame
- Section 8 – Body
- Section 9 – Brakes, Brake Components, Wheel Hub
- Section 10 – Suspension, Suspension Components, Springs, Shocks and Steering
- Section 11 – Steering Components, Wheels, and Tires
- Section 12 – Safety Equipment
- Section 13 – Electronics, Gauges and Dash Modules
- Section 14 – Miscellaneous
- Section 15 – Drawings (Provided by the World of Outlaws Late Models)

All Rules in **BLACK** are from the Unified Dirt Late Model Car Construction Rules (provided by WOO)  
<https://dirtcar.com/rules/series-rules/world-of-outlaws-late-model-series/>

All Rules in **BLUE** are specific to the Super Late Model Racing Series (SLMR).

All Rules in **RED** are changes made for the 2026 season.

Required SLMR safety bonus money rules are in **PURPLE** for 2026 season.

\*If there are any interpretations between the unified rules and the SLMR Series Rule book, SLMR Rules in Blue or Red will supersede the duplication of the rule that is written in black.\*

## Section 1 – Engines

A. V8 engines sized 350ci. – 460 ci. may be used (aluminum block, steel block, aluminum head, steel head), restrictors and weight rules will serve as equalizers. **Restrictors cannot be bigger than what is listed per engine but can be smaller.** See weight rule in each motor sub-section.

### B. Engine Set-Backs

- a. All competing models using an engine larger than 364 cubic inches G.M., Ford, Chrysler, are allowed a maximum engine set back of 26 inches.
  - i. To be measured on the left side of the engine from the front side of the rear engine plate to the center of the upper A frame/control arm mounting bolts which should be equal to the center of the ball joint.
- b. All competing models using a G.M., Ford, Chrysler steel block engine 364 cubic inches or smaller or a crate 525 engine will be allowed a maximum engine set back of 28 inches using the same measuring technique as listed in section B-a.
  - i. Any fraction over 28 inches, there will be a 25lb lead weight penalty up to 30 inches to be placed in front of the rear motor plate.
- c. Any cubic inch using an aluminum block motor excluding the 525 crate that measures between 26 inches up to 28 inches need to add 25 pounds. Measurements between 28 inches to 30 inches need to add 50 pounds.
- d. Any measurements over 30 inches as listed in B-b and B-c, needs to add an additional 25 pounds per inch. Measurements over 32 inches will be at the discretion of the SLMR tech official.
  - i. For example; 30 1/8 inch will need an additional 25 pounds added. 31 1/8 with be another 25 pounds. No car will be allowed to run over 32 inches.

### C. SLMR Spec Headed Engine Rules

- a. Any cast iron block only, List of part numbers for heads will be listed at a later time. The Brodix Spec 40/60 heads will not be allowed such as ASCS/SUPR.
- b. Over 364 cu inches or 364 cu inches and under.
- c. Aluminum intake. 7 inches from bottom of plenum to base of carburetor, including any cataloged spacer plate, including super suckers, and gaskets.
- d. Approved Brodix Spec Aluminum heads allowed.
  - i. Allowed part numbers include:
    - a. Chevrolet – SPCH
    - b. Ford - SPFO, Mopar
    - c. SPMO.
  - ii. **May grind all IMCA spec heads with all of the same rules stated in rule 1 section C. a. thru i. including restrictors and weights.**
- e. Absolutely NO removing, relocating, grinding, polishing or defacing of any letters or numbers cast into the Brodix Spec aluminum cylinder heads.
- f. Heads may be angle milled, although valve angle must remain within (two) 2 degrees of original manufactured specification.
- g. Valve guides must remain in original angle and spacing as manufactured. Valve guides may not be tapered, thinned, or shortened in any way.
- h. Absolutely no welding or adding material of any kind to the head.
- i. Removal of material from the head is only allowed as listed below:
  - i.. Chamber may be ground for dome clearance and polished.
  - ii.. Intake Port - Intake bowl may be blended and polished from the valve seat to the edge of the letter C in the word “Spec” on the roof and floor of the intake port. The side of the intake port may also be blended and polished from the valve seat to the same point as the roof and floor. Absolutely no grinding or polishing along the sidewalls where the spec logo is cast. Factory CNC port match must not be altered in any way.
  - iii.. Exhaust Port - Exhaust seat may be blended into the exhaust bowl and exhaust port may be polished as long as the word “Spec” in the roof of the exhaust port is not touched and the exhaust port exit at the header flange remains in the original as cast location, size and shape.

- iv. May machine for pushrod clearance.
- j. Absolutely no enlarging, relocating or other altering of any head bolt hole, dowel hole, or threaded hole in the head except as noted below:
  - i. May spot face head bolt holes after angle milling head.
  - ii. Heli coils may be used for repairs.
  - iii. Absolutely no grinding or polishing of or any kind anywhere on the casting, except in the combustion chamber, and in the areas of the intake port and exhaust ports as stated above, and for pushrod clearance.
- k. Any internally repaired spec head must be recertified by Brodix.
- l. Spec head checking fixtures will be used by SLMR officials to check all specifications and dimensions listed above.
- f. STEEL BLOCK ONLY: Maximum 364 cu inches Brodix Spec Headed** must weigh minimum 2350 lbs.
  - i. Fuel must be gasoline, ethanol-enriched gasoline, or alcohol.
  - ii. No oxygenated fuel other than methanol or ethanol is allowed.
  - iii. No nitrous oxide, or nitro.
  - iv. No nitrous devices allowed.
  - v. No nitro-methane or propylene oxide.
  - vi. **When running anything but 100% gasoline, you must add 40lbs to the front of the rear motor plate.**
- g. STEEL BLOCK ONLY: Brodix Spec Headed engine larger than 364 cu inches** – Gasoline Only, minimum weight 2350 lbs. with (4) 1.200 restrictors **Wehrs insert plate with 1.200**

#### D. IMCA Spec Engine Rules

- a. Steel blocks only. Maximum 361 (GM), 362 CI (Ford), and 364 CI (Chrysler)
- b. Minimum four-inch bore
- c. Minimum stroke: 3.48 inch (GM), 3.40 inch (Ford), and 3.313 inch (Chrysler)
- d. Maximum compression – 10.5 to 1, can be checked at any time with whistler. With a 0.1 tolerance for carbon build up.
- e. Read intake manifold Section 1-K**
- f. Brodix/IMCA spec cylinder heads only. No grinding, polishing, **or altering of any kind**. No use of any substance that may change or alter shape or size of ports, runners, or combustion chambers. Only alterations allowed to heads are for push rod clearance and to install shaft rocker system.
- g. Maximum valve sizes are 2.08 intake and 1.600 exhaust. Valve seats and guides to remain as manufactured and in as-cast positions. Minimum combustion chamber size to be 62cc volume. Valve angle to remain as manufactured.
- h. Approved cylinder heads as follows: GM – Brodix # 46 221, Ford – Brodix # 46 223, Chrysler/Mopar – Brodix # 46 222. No modifications to intake manifolds, must be used as produced by manufacturer. List of approved intakes as follows: GM – Brodix #HV100946, Ford – Edelbrock #2981 or 2980 (351) or #2921 (302), Chrysler – Edelbrock #2915.
- i. Camshafts may be of roller, flat tappet or mushroom design.
- j. Crankshafts and connecting rods must be steel.
- k. One-inch inspection hole required in pan – no obstructions to crank and rods. If obstructions are present, must remove pan for inspection. Flat top pistons only.
- l. Crank triggers, you will only able to run off one of **two** firing option, crank trigger or distributor-may be changeable within reach of driver or within driver cockpit. Both firing options must be within 2 degrees when read with the timing light of the tech official.
- m. STEEL BLOCK ONLY: IMCA Spec Motor** 2300 lbs. With up to a 10" spoiler with the standard 8-inch braces. Gasoline Only, if you run a different fuel (ethanol-enriched gasoline, or alcohol) your weight minimum will increase 2350lbs. With 25lbs of additional weight being added to the front of the engine plate. No oxygenated fuel other than methanol or ethanol is allowed. No nitrous oxide, or nitro. No nitrous devices allowed. No nitro-methane or propylene oxide.

#### E. GM Crate Engine Rules

- a. 602, 604, and 525 must have GM sealed bolts or IMCA sealed bolts
- b. Any parts that have been replaced or repaired must be done to the weight, size, and material specs of

GM as stock purchase.

**c. STEEL BLOCK ONLY: 602, 604 GM crate Motors**, 2250 lb. weight minimum with up to a 10" spoiler with the standard 8-inch braces. Fuel must be gasoline, ethanol-enriched gasoline, or alcohol. No oxygenated fuel other than methanol or ethanol is allowed. No nitrous oxide or nitro. No nitrous devices allowed. No nitro-methane or propylene oxide.

**d. Aluminum Block Crate GM CT525: Must weigh minimum 2275 lbs.** Fuel must be gasoline, ethanol-enriched gasoline, or alcohol. No oxygenated fuel other than methanol or ethanol is allowed. No nitrous oxide, or nitro. No nitrous devices allowed. No nitro-methane or propylene oxide. When running anything but 100% gasoline, you must add 25lbs to the front of the rear motor plate.

#### F. Chevrolet Motors 23-Degree Track 1 Open Head without the spec or series bosses.

a. STEEL BLOCK – ALUMINIUM HEAD: Chevrolet Motors with Brodix 23-degree track 1 style open head Under 374 cu in. must weigh minimum 2350 lbs. Gasoline Only.

i. With a 23-degree valve angle of plus or minus 2 degrees with the valve center of 2.350 to 2.354 with (3) at 1.150 restrictors (1) 1.200 restrictor. **Wehrs insert plate with 1.1625**

ii. With a 23-degree valve angle of plus or minus 2 degrees with the valve center of 2.349 or less with (1) at 1.100 restrictors and (3) at 1.150 restrictors. **Wehrs insert plate with 1.1375**

b. STEEL BLOCK – ALUMINIUM HEAD: Chevrolet Motors with 23-degree track 1 style open head Over 375 cu in. Must weigh minimum 2350 lbs. Gasoline Only.

i. With a 23-degree valve angle of plus or minus 2 degrees with the valve center of 2.350 to 2.354 with (4) 1.100 restrictors **Wehrs insert plate with 1.100**

ii. With a 23-degree valve angle of plus or minus 2 degrees with the valve center of 2.349 or less with (2) at 1.100 restrictors and (2) at 1.050 restrictors. **Wehrs insert plate with 1.075**

#### G. LS, Open Aluminum, or steel motors

**a. LS, Open Aluminum, or steel motors** with unrestricted valve angle 400 cubic inch and under must weigh 2350 lbs. with (1) 1.000 restrictors and (3) 1.050 restrictors. Gasoline Only. **Wehrs insert plate with 1.0375**

**b. LS, Open Aluminum, or steel motors** with unrestricted valve angle 401 cubic inches and larger must weigh 2350 lbs. with (2) at 1.000 and (2) at 1.050 restrictors. Gasoline Only. **Wehrs insert plate with 1.025**

#### H. LS Chevy Style Concept Engine Rules Coming

##### I. Steel Head Engine Rules (Small Cubic Inch)

a. Only O.E.M. stock production steel heads as numbered below will be allowed.

b. No Dart, fuel injected, Ford Cleveland, or GT40 heads allowed.

c. The specified (spec.) head will be the G.M. BOWTIE non-vortec cylinder head, part/casting number 10134392, 14011058, 12480034, or 14011034. Chevrolet Performance Vortec Part number 12558060. Casting number 12039906 or 12558062 that have a 64CC combustion chamber, a 170CC intake port, no alterations to the head including porting or polishing and valve size must remain stock. 1.940" intake valve and 1.500" exhaust valves are legal.

d. Ford M-6049-n351, Mopar head casting number 4532693. Mopar may run Chrysler R block #P4532907 or P4532908. Mopar heads may be 15 or 18 degrees. O.E.M. J Design Mopar heads are not legal. No modification outside of the combustion chambers, except surfacing, three angle valve jobs, and touching up the combustion chamber.

e. Titanium valves and retainers allowed.

f. All cylinder heads under Section 1.I.c and 1.I.d listed above must remain with their stock production valve centers.

g. Roller camshaft, lifters, and rocker arms will be allowed. Shaft rockers will be allowed.

h. Any aluminum intake may be used with a maximum total height of 7" from the carburetor base plate including the spacer plate to the floor of the plenum. Up to a 2" spacer/super sucker may be included in the 7" height. No super high-rise intakes allowed. Plenum must have flat floor.

i. No titanium engine parts, except titanium valves and retainers.

j. Engine casting numbers stamped on the engine will be left on the block at the bell housing area.

k. No epoxying of block numbers will be allowed. Block numbers will be stamped by inspector if needed

**I. STEEL BLOCK ONLY: 364 cu inches or smaller all steel motor including heads** must weight minimum 2350 lbs. Fuel must be gasoline, ethanol-enriched gasoline, or alcohol. No oxygenated fuel other than methanol or ethanol is allowed. No nitrous oxide, or nitro. No nitrous devices allowed. No nitro-methane or propylene oxide. When running anything but 100% gasoline, **you must add 25lbs to the front of the rear motor plate.**

#### J. Cylinder Heads

- a. Any eligible cylinder head may be used. Approval of cylinder heads means approval for all competitors within the same guidelines.
- b. There will be a competitor or track protest rule within 10 minutes after the A-Feature checkered flag for \$1,800 for one-cylinder head or \$2,200 for both cylinder heads for IMCA, Wisconsin, SB2, GM Crate or factory steel untouched heads. This rule only applies when there is a minimum of five business days between the next Series' race. IMCA and Wisconsin heads will be sent to Brodix to be ensured they are stock approved heads for each series. SB2, GM Crate, or factory steel untouched heads will be sent to Speedway Motors to be checked for illegal porting or air flow increase.
- c. A competitor can only protest the same competitor one time during the season.
- d. When running SB2 heads they may be tested with a chemical, such as ether, to check for increased outside air flow.

#### K. Intake Manifolds

- a. Intake manifolds for the crate engines (602, 604, 525) must remain as manufactured and purchased for the crate motor. Up to a 2" super sucker may be used.
- b. IMCA intake must be stock configuration as purchased for IMCA racing, may use up to a 2" spacer including a super sucker. (Inside of the bottom intake manifold must be flat. No devices permitted inside of intake manifold to disrupt/enhance the air flow to the engine).
- c. IMCA Chevrolet intake manifold may have the clover milled out to be an open intake. The sides must not be milled any bigger than stock and the ports and runners must not be changed from stock IMCA manifold. Spacer of up to a 2" may be added to this intake, super sucker may be used. The measurement of the allowed cutting will be 3.625 across and 3.625 front to back at the top of the intake where the carburetor plate is mounted. It may go down into the intake up to the maximum of 1" from the top of the intake where the carburetor gasket mounts and no farther than 90 degrees from the carburetor gasket surface. It may be less than 90 degrees no other grinding will be allowed inside the intake runners or fuel guide fins.
- d. Intake Manifolds on a Wide Bore Engine may configure to be taller than 6" with a 1" spacer & a 1" restrictor/governor. **Overall two-inch (2") maximum height.** No Super Suckers.
- e. Intake manifolds may be used with a total height of 7" including any spacer, restrictor, and gaskets from floor of plenum to the opening of the carb spacer pad. Intake manifolds must have a minimum of a 3.500-inch opening in any direction front to back or side to side at the top of the carb spacer pad to the base of the plenum which must contain no obstructions except for the blades of the runners and restrictor/governor plate, ~~no super-sucker.~~

#### L. Spacer Plates

- a. Restrictor/governor plates 1" thick Keyser Manufactured part #100 125000 and must use inserts/restrictor sizes 100 125095, 100 125100, 100 125105, 100 125110, 100 125120, 100 125125, 100 125130, and 100 125135. **Or Wehrs reduction system spacer plate, insert restrictor sizes are located in Section 1.C - 1.F - 1.G.**
- b. You may use 1 or 2 Spacer plates not including your restrictor/governor plate to hit maximum intake height. Spacer plates may be open style or 4-hole spacer plate, must be unaltered and be a cataloged part number through Keyser Manufacturing/Port City, Speedway Motors, or Wehrs Machine and purchasable for all competitors, with zero tolerance taper to enhance or increase the airflow to the engine.
- c. Wehrs Machine, part number WM101250R 1" may be used on a 401 & larger motor under section 1.G.b (part number must be legible at all times, no grinding or enhancing of plate, must remain stock), may be used under the 1" governor/restrictor plate. No alteration to the plate. No weight penalty will be assessed when using this plate.

d. Restricted motors rule any restricted motor will be allowed to use the angled restrictor plate by Allstar Performance part #ALL25977. 15lbs needs to be added to the front of the rear engine plate to be able to use Allstar Performance restrictor plate #ALL25977 as it is built to use the same restrictor cones as the Keyser plate. The height of the intake from the bottom of the plenum to the top of the spacer plate must maintain the same intake height rule at the highest point as what is posted for your engine option.

e. Starting in 2026, Wehrs spacer plate # will be allowed with the following plate inserts from Wehrs for the following engine combinations

- i. Steel Block - Brodix Spec Headed engine larger than 364 cubic inches Wehrs # 1.200 plate insert
- ii. Steel Block – Aluminum Head: Chevrolet Motors with Brodix 23-degree track 1 style open head Under 374 cubic inch valve center of 2.350 to 2.354 Wehrs 1.1625 plate insert
- iii. Steel Block – Aluminum Head: Chevrolet Motors with Brodix 23-degree track 1 style open head Under 374 cubic inch valve center of 2.349 or less Wehrs 1.1375 plate insert
- iv. Steel Block – Aluminum Head: Chevrolet Motors with Brodix 23-degree track 1 style open head Over 375 cubic inch valve center of 2.350 to 2.354 Wehrs 1.100 plate insert
- v. Steel Block – Aluminum Head: Chevrolet Motors with Brodix 23-degree track 1 style open head Over 375 cubic inch valve center of 2.349 or less Wehrs 1.075 plate insert
- vi. LS, Open Aluminum, or steel motors 400 cubic inch and under Wehrs 1.0375 plate insert
- vii. LS, Open Aluminum, or steel motors 401 cubic inch and larger Wehrs 1.025 plate insert

## Section 2 – Transmission, Driveline and Driveline Components

### A. Transmission

- a. A functional clutch must be used. Direct drives systems of any type will not be permitted.
- b. The transmission must be bolted to a bellhousing, bellhousing must be bolted to the engine.
- c. The transmission must have forward and working reverse gear(s) and must be able to shift to forward or reverse with the engine running.
- d. Only two-speed transmissions with a working reverse low gear and high gear will be allowed. High gear is one (1) to one (1).
- e. No overdrive or underdrive multiple speed transmissions will be permitted.

### B. Driveshaft

- a. The driveshaft must be a minimum of two inches (2”) in diameter. All drive shafts must be painted white.
- b. Only one (1) driveshaft connected from the transmission to the center section of the rear end will be permitted.
- c. A minimum of one (1) driveshaft hoop/sling must be fastened securely to the frame.

### C. Rear End

- a. Any type of rear-end differential/center section will be permitted.
- b. Independent rear suspensions will not be permitted.
- c. Full-floating hubs manufactured of either aluminum or magnesium with “wide 5” wheel bolt pattern must be used.
- d. The axle housing must be of the “closed-tube” design utilizing “full-floating” magnetic steel axle shafts.
- e. The center section of the axle housing must be manufactured of either aluminum or magnesium.
- f. Axle tubes must be one (1) piece. Axle tubes must be manufactured of aluminum or magnetic mild steel. Axle tubes manufactured of exotic; heavy materials will not be permitted. The outside diameter of the axle tubes must not exceed three inches (3”). Axle tube internal inserts or external sleeves will not be permitted. The addition of any ballast weight to the axle housing will not be permitted.

## Section 3 – Fuel, Fuel Cells, and Fuel System

A. Fuel cells must meet or exceed FIA/FT3 or SFI 28.3 specifications. The fuel cell must have a maximum capacity of thirty-five (35) gallons, prior to foam.

- B. The fuel cell must be enclosed in a container with a minimum thickness of twenty (20) gauge magnetic steel or sixty thousandths of an inch (.060") aluminum.
- C. Fuel cell cap must be a threaded cap and/or ATL Part # TF751 quarter (1/4) Turn Bullet Cap, Schultz Racing Fuel Cell part #SFP-300 quarter (1/4) turn cap.
- D. The entire container must be visible for ease of inspection.
- E. The fuel cell must be mounted behind the rear axle between the rear tires, a minimum of four inches (4") ahead of the rear bumper. The bottom of the fuel cell must not be any lower than the bottom of the rear end/quick-change housing.
- F. Fuel cells that are not contained within a welded steel tubing "rack" must have two (2) equally space straps that measure two inches (2") wide by one eighth inch (1/8") in thickness that surround the fuel cell. The straps must be bolted to the frame. Longitudinal (front to rear) orientation is recommended for strap mounting.
- G. Fuel valve plate, fuel pickup, and fuel return fittings must be on the top of the fuel cell.
- H. Only racing gasoline or alcohol will be permitted for competition (Alcohol is only permitted for GM Sealed Crates 602, 604, & 525 and under 364 cu in Brodix spec headed engines and stock steel headed engines. Check specific engine rule for weight to be added to the mid motor plate). Nitrous oxide, nitromethane, and/or propylene oxide will not be permitted.
- I. Competitors must be prepared to drain fuel from the fuel cell for inspection.
- J. Mechanical fuel pumps must be used. Fuel pumps must be engine mounted. Fuel pumps may be camshaft actuated or belt driven. Electric pumps, primary and/or secondary, pressure systems, and additional reservoirs will not be permitted.

#### **Section 4 – Electrical Systems, Batteries, Electrical Accessories**

- A. The battery must be securely mounted with positive fasteners and brackets. All battery supports and/or mounts must be secure and braced in two (2) horizontal positions and one (1) vertical position.
- B. The battery terminals must be insulated, and the battery enclosed with a non-conductive material that will prevent contact with any part of the race car should the battery become dislodged from the battery mount.
- C. One (1) mandatory battery disconnect switch must be installed on the rear deck, behind the driver seat, in a location that is easily accessible from outside the race car. The switch must be clearly labeled with off/on direction. The switch must be directly in-line with the negative battery cable and be capable of completely disconnecting the negative terminal of the battery from the race car. Negative or "ground" wiring connections must not be made anywhere from the battery negative terminal to the input side of the disconnect switch.
- D. No batteries are permitted in the driver's compartment/ cockpit.

#### **Section 5 – Exhaust, Muffler, and Sound Reduction Devices**

- A. The exhaust flow must be parallel to the ground. Exhaust systems that direct the flow toward the ground will not be permitted.
- B. All exhaust systems/headers must end with a collector.
- C. Several tracks have a locally enforced decibel rule, which preempt any particular muffler rule. Some tracks may have a maximum sound level rule of ninety-five (95) decibels at one-hundred feet (100'). This rule will be enforced by local government agencies.
- D. If a decibel rule is in place, then the decibel rule must be met, regardless of the specified muffler application.

#### **Section 6 – Ignition Boxes, Traction Control, Radio & Transmission Devise**

- A. All electronic and/or computerized wheel spin and/or ignition retardation and/or acceleration limiting and/or traction control devices of any type will not be permitted.
- B. Adjustable ping control devices, dial a chip controls, timing controls, and/or automated throttle controls will not be permitted.
- C. Adjustable restrictor plates will not be permitted.
- D. Remote control components of any type will not be permitted.
- E. Radios and/or devices for transmitting voice and/or data will not be permitted.
- F. Data acquisition systems will not be permitted.
- G. GPS and/or any type of electronic tracking and/or locating devices will not be permitted.

#### **Section 7 – Chassis and Frame**

## A. Chassis

- a. The minimum wheelbase will be one hundred three inches (103") with a maximum wheelbase of one hundred five inches (105").
- b. Frames fabricated using square tubing must be a minimum of two inches (2") x two inches (2") magnetic steel with a minimum material thickness of eighty-three thousandths of an inch (.083").
- c. Frames fabricated using round tubing must be a minimum of one and three quarters of an inch (1-3/4") outside diameter magnetic steel tubing, 4130 chrome moly, Docol, or DOM with a minimum material thickness of eighty-three thousandths of an inch (.083").
- d. Rear bumpers that are stubbed may only extend a maximum of eight inches (8") beyond the frame. Any stubbed rear bumper that extends further than the maximum of eight inches (8") must be formed and directed eight inches (8") toward the front of the car.
- e. All battery supports and/or mounts must be secured and braced in two (2) horizontal positions and one (1) vertical position.
- f. The manufacturer's unique serial number should be displayed on every chassis.
- g. No aluminum frames, door bars, or bumpers permitted.
- h. No titanium fasteners, chassis components, or suspension components.
- i. All cars must have a left side under-slung bar. The left rear under-slung rail must be located between the left rear birdcage and the edge of the left rear axle housing bell. The bar must pass underneath the left side axle tube.
- j. No slip joints permitted. All joints must be welded.**

## B. Roll Cage

- a. All cars must have a roll cage fabricated from a minimum of one and one-half inch (1-1/2") outside diameter with sixty-five thousandths of an inch (.065") thick seamless magnetic steel tubing.
- b. The side roll bars and/or door bars must extend into the door panels.
- c. A minimum of three (3) one and one-half inch (1-1/2") outside diameter bars sixty-five thousandths of an inch (.065") in thickness must be utilized on the left side of the car in the door area.
- d. Roll cage must be above the driver's helmet thirty-eight inches (38") minimum between floor pan and the bottom of the roll cage.
- e. The entire roll cage must be constructed of round tubing only.
- f. No slip joints permitted. All joints must be welded.**

## C. Driver Side Intrusion Plate

- a. A minimum one-eighth inch (1/8") thick magnetic steel intrusion plate on the driver's side door bars is mandatory.
- b. Approved installations:
  - i. Welded plates- Individual plates between door bars are permitted but must be welded around the perimeter of each opening. The minimum area covered is sixteen inches (16") by twenty-six inches (26").
  - ii. A minimum of sixteen-inch (16") x twenty-six-inch (26") plate bolted to fabricated one-eighth inch (1/8") magnetic steel tabs, welded securely to the chassis, using a minimum of eight (8) x three-eighths of an inch (3/8") Allen button head bolts. A minimum of three (3) fabricated one eighth of an inch (1/8") magnetic steel tabs and three-eighths of an inch (3/8") Allen button head bolts required across the top of the intrusion plate, a minimum of three (3) fabricated one-eighth of an inch (1/8") magnetic steel tabs and three-eighths of an inch (3/8") Allen button head bolts required across the bottom of the plate, and one (1) fabricated one-eighth of an inch (1/8") magnetic steel tabs and three-eighths of an inch (3/8") Allen button head bolt in each in the middle front and middle rear of intrusion plate.
  - iii. A minimum of sixteen-inch (16") x twenty-six-inch (26") plate bolted to a minimum of six (6) approved-design door bar clamps using the included twelve (12) x one-half-inch (1/2") Allen button head bolts per the manufacturer's specification. A minimum of three (3) approved-design door bar clamps and the included six (6) x one-half-inch (1/2") Allen button head bolts required across the top of the intrusion plate and three (3) approved-design door bar clamps and included six (6) x one-half-inch (1/2") Allen button head bolts required across the bottom of intrusion plate. The vendor and part number must be clearly labeled on the part.
  - iv. Currently approved door bar clamps:

1. Bicknell Racing Products – Part Number: BRP 954
2. Wehrs Machine & Racing Products – Part Number: WM397
3. Allstar Performance – Part Number: ALL4198

#### D. Weight and Ballast

##### a. See your engine option in Section 1 for your total weight rule.

##### **No fuel burn off allowance.**

- b. Any attached weights must be securely attached to the frame, painted white, and have the car number clearly displayed on them. All weights must be secured by two (2) one-half-inch (1/2") Grade 5 or higher bolts on two (2) weight clamps per piece.
- c. Additional added weight(s) must be securely attached to the frame below the body decking. i. Frame is defined as the steel welded structure only.
- d. Any part that moves or is not a fixed component to the steel frame structure may not be used for any additional weight attachments.
- e. Additional added weight(s) attached to the rear bumper and/or outside the frame will not be permitted.
- f. Any car that loses any weight/ballast during an event may be subject to a penalty.
- g. Pellet-type and/or liquid-type weight/ballast will not be permitted.
- h. Driver-operated weight adjustment, 'weight jacking' devices will not be permitted.
- i. The scale(s) used for the event, provided by the series or the track will be considered the official scales for the event.
- j. Scale(s) will be available for all teams to verify their car weight and determine the scale weight.
- k. In the event of a car not meeting the required overall weight, Officials may allow a car to re-weigh up to two (2) additional times by removing the car from the scale(s) and repeating the weighing procedure. If a car is allowed to re-weigh the overall weight of the car recorded during the final weighing procedure will be the "official" weight of the car.

#### Section 8 – Body

##### A. General Body

- a. All cars must have a minimum one-half-inch (1/2") and a maximum of one-inch (1") radius at the top of fenders, doors, and quarter panels. Sharp edge(s) will not be permitted.
- b. The floorboards and firewall must completely cover the driver's area with no openings.
- c. Fins and/or lips of any type will not be permitted anywhere along the entire length of the car.
- d. Wedge shape cars and/or body styles will not be permitted.
- e. "Belly pans" or any type of enclosure on the bottom of the car will not be permitted. A skid plate to protect the oil pan is permitted. A maximum one-eighth inch (1/8") skid plate will be permitted.
- f. Wings and/or tunnels and/or any type of air deflection device will not be permitted underneath the body and/or chassis of the car.
- g. A maximum of one (1) stone deflector, for rear mounted oil pumps, oil filters, and for the main oil tank will be permitted. The deflector may be made of steel, aluminum, or heavy gauge wire. The cover may only be mounted near the unit it is designed to protect only mounted from the upper right frame rail to the lower right frame rail. The deflector may extend from the mid plate and stop at the front of the four-bar plate.
- h. Panels of any type under the rear deck running from the front to the rear of the car will not be permitted.
- i. Any style air cleaner scoop used must be positioned in front of/or around the air cleaner and must not exceed seven inches (7") in height. Any type of flange and/or air deflection device and/or fin that is designed to direct airflow will not be permitted.
- j. The top edge, measured from the ground, of the rear quarter, door, and front fender to the point where the fender flare attaches must be a straight line, within one inch (1") on both sides of the car.
- k. All body panels must be solid. No holes, slots, or air gaps are permitted. NACA ducts or NACA style ducts are not permitted. One (1) hole for interior (deck) mounted oil cooler is permitted.
- l. The minimum ground clearance (including plastic) is three inches (3").

##### B. Nosepiece

- a. Only approved nosepieces will be permitted. Currently approved nosepieces:
  - i. Dominator (must fit MD3 template)

- ii. MD3 – Performance Bodies
  - iii. ARP Air Speed Nose
  - iv. Five-Star MD3 type
  - v. Performance Bodies/Five Star MD3 2015
  - vi. Performance Bodies / Five Star 2016 Evolution
  - vii. Performance Bodies / Five Star 2019 Evolution 2
- b. Approved nose assemblies must be installed per the manufacturer's instructions. All nose assemblies must meet the maximum/minimum dimensions, maintain manufacture appearance, and not be altered.
  - c. All nosepieces must be made of molded type material.
  - d. Nose filler panel shall be flat, within one-half inch (1/2"), across to entire surface, dishing or raising is prohibited. Bracing and structure underneath filler panel must maintain flat shape on the track at speed at the discretion of the technical director.
  - e. Two-piece noses must be positively fastened together in the center. Spacers added to gain width will not be permitted.
  - f. The nosepiece must be mounted flat where filler panel and nosepiece meet. The nosepiece must be mounted in a manner that does not alter its original shape. The nosepiece will be checked with a template by pushing against the mounting supports to gauge its profile against the template.
  - g. Holes for cooling purposes must be within ten inches (10") from the center point of the nose (where the left and right panels of nose and/or valance come together).
  - h. The nosepiece can extend a maximum of fifty-three inches (53") from the center of the front hub to the farthest point extending forward.
  - i. The front fender flairs can extend a maximum of four inches (4") above the filler panel or the hood.
  - j. The nosepiece of the car must be mounted within a maximum of five inches (5") off-center when measured at the center/overlap of the nose.
  - k. Lower nose supports (support under front bumper at valance) must not exceed eight inches (8") in width.

#### C. Roof

- a. The roof length from front to back must be a minimum of forty-four inches (44") with a maximum of fifty-four inches (54").
- b. The roof width from side-to-side must be a minimum of forty-eight inches (48") to a maximum of fifty-two inches (52").
- c. The roof must be mounted with positive contact to all four (4) corners of the roll cage with a minimum of four (4) bolts, one near each corner, with no spacers.
- d. The roof must be mounted parallel to the body and near the center of the car as viewed from the front of the car.
- e. A maximum one and one-half inch (1-1/2") roll, turned downward will be permitted along the front edge of the roof. A maximum one-inch (1"), ninety-degree (90°) bend, will be permitted along the rear edge of the roof. These modifications will be permitted to improve the strength of the roof. Any other modifications to the roof will not be permitted.
- f. Flat and/or odd-shaped roofs will not be permitted. Bellied and hollowed roofs will not be permitted.
- g. Sun/anti-glare shields may not be used.
- h. A maximum of two (2) roof edge bead rolls with a maximum height of one-half inch (1/2") the length of the roof will be permitted.
- i. The maximum thickness of the roof at any point will be one-half inch (1/2").
- j. The roll cage and associated frame members above the interior panels (decking) must remain open. Enclosures will not be permitted.

#### D. Roof Supports and Window Side Panels

- a. All roof side panels must extend to the edge of the body.
- b. The left and right sail panels must be between fifteen inches (15") and seventeen (17") at the top; between forty inches (40") and forty-three (43") inches at the bottom.
- c. The window area may be covered with clear Lexan or transparent material. Both window openings must be covered, or both must be left open.
- d. If sail panels are left open, they must maintain a border frame of two inches to three inches (2-3") at the top and sides, and three inches (3") at the bottom.
- e. The maximum inside radius of either sail panel is three inches (3").
- f. The left and right window panels must match.

- g. A maximum bow of two inches (2") outward on the window side panels as viewed from behind will be permitted.
- h. The front roof supports must extend forward to the rear of the hood. The front roof supports may be a maximum of four (4") wide. The left and right front roof supports must match.
- i. A minimum of three inches (3") is required between sail panel and spoiler support.

#### E. Front Fenders, Fender Flares, and Hood

- a. The hood must be level and flat from the left to the right side of the car.
- b. The hood can drop two inches (2") measured at the back edge of the hood and in from of the carburetor from the left to the right side of the car. Fenders must taper from outer edge to the hood in a straight line.
- c. The fender top must have a ten inch (10") minimum width.
- d. The outside edges of the hood and/or the fender must remain inside the overall bodyline.
- e. The front fender must be a minimum of thirty-six inches (36") and maximum of thirty-eight inches (38") in height, measured vertically from the ground to the top of the fender behind the front tires.
- f. The front fender flares must be made of plastic and must not alter the original shape of the nose piece.
- g. The front fender flares must not extend beyond the front tires, with the wheels pointed straight, more than one inch (1") per side to a maximum width, edge-to-edge, of ninety-one inches (91") when measured at the widest point at the bottom of the valance.
- h. Front fender flairs must not extend, bubble, or rise more than four inches (4") at any point of the front fenders and/or hood.
- i. The front fender flares must have collapsible supports.

#### F. Doors

- a. The door-to-door measurement must not exceed seventy-seven inches (77") in width at the top of the doors.
- b. The door-to-door measurement must not exceed ninety inches (90") in width when measured at the bottom of the doors in the center of the car (including plastic).
- c. The door-to-door measurement must not exceed ninety-four inches (94") in width when measured at the bottom of the doors at the widest point of the car (including plastic).
- d. The doors must not exceed thirty-seven (37") in height when measured from the ground to the top of the door.
- e. The door sides may not bow inward more than one inch (1") from top to bottom (including plastic)
- f. Plastic door panels are permitted on left and right side of car.

#### G. Quarter Panels

- a. The maximum distance from the center of the rear hub to the top quarter of the panel is fifty-four inches (54").
- b. The quarter panel must not exceed seventy-six inches (76") in width at any point as measured at the top of the panel.
- c. The rear deck must taper from where the quarter panel and door meet to the rear spoiler with a minimum width of seventy-two inches (72") and a maximum width of seventy-six inches (76").
- d. The maximum width for the quarter panels measured from outside-to-outside (including plastic) is eighty inches (80").
- e. The quarter panels may not break inward more than one inch (1") from top to bottom (including plastic).
- f. The maximum distance from the center of the rear hub to the rear trailing edge of the quarter panel is forty-nine inches (49").
- g. A minimum of two inches (2") of tire clearance between the tire and the body will be required.
- h. Left rear wheel opening between the quarter panel and the door must be a minimum of twenty-eight inches (28") with a maximum of thirty-three inches (33").
- i. Right rear wheel opening between the quarter panel and the door must be a minimum of twenty-nine inches (29") with a maximum of thirty-two inches (32").
- j. Skirting that extends behind the rear quarter panel will not be permitted.
- k. Left rear quarter panels must extend downward from the deck a minimum of thirty-three (33") and a maximum of thirty-six inches (36") (including plastic) when measured at the front and rear of the quarter panel.

- l. The right rear quarter panel must extend downward from the deck twenty-seven inches (27") without plastic, or thirty-one inches (31") with plastic when measured at the front and rear of the quarter panel.
- m. Deck height will be measured at the nose piece splitter at a max height of fifteen inches (15") from the ground to the top. Deck height must be thirty-nine inches (39") from the top of the rear deck to the ground.
- n. Plastic or Stakt quarter panels are permitted on the right or left side.

#### H. Right Side Body

- a. The quarter panel, door (to the fire wall) must be within one inch (1") of a straight line in all directions when measured at the top of the body.
- b. The quarter panel, door, and fender (to the fender top) must be within two inches (2") of a straight line in vertically when measured at the top of the body.
- c. The quarter panel and door must be within one inch (1") of a straight line where the skirting joins the door and the quarter panel.

#### I. Spoilers, Spoiler Braces and Spoiler Supports

- a. Only aluminum rear spoilers will be permitted. A plastic breakaway panel of twenty-one inches (21") is permitted. All spoiler sides and braces must be aluminum.
- b. The maximum overall height of the rear spoiler is eight inches (8"). **The maximum width of the rear spoiler, including braces and/or supports, is seventy-two and three-eighths of an inch (72-3/8").**
- c. The rear spoiler must begin at the deck and extend eight and one-quarter of an inch (8-1/4") from that point. Mounting hardware, hinges, etc. will be included in the eight and one-quarter of an inch (8-1/4") measurement. Suspending the spoiler to create a wing-type device will not be permitted.
- d. The rear spoiler must begin at the rearmost point of the quarter panels.
- e. Only three spoiler braces/supports will be permitted. The front edge of the spoiler brace/support must be in line with the spoiler.
- f. The outside spoiler supports must not be mounted any wider than the top of the quarter panel(s) and must be centered on the rear deck.
- g. In the event that aluminum angle is used to brace the upper edge of the spoiler, the angle must not add to the height and/or length of the spoiler in any way.
- h. The spoiler must be a single plane from top to bottom.
- i. **No offset spoiler sides permitted. Each spoiler side must be positioned in the same place at the T-bar on both left and right sides.**

#### J. Interior

- a. The interior is permitted to be dropped to the middle (just behind the seat) of the car a maximum of five inches (5") below the top of the doors and minimum of twelve inches (12") below the roll cage.
- b. The side window opening(s) must be fifteen inches (15") from the top of the door to the bottom of the roof.
- c. Support bars that block the right window from the driver exiting the cockpit will not be permitted.
- d. A rock guard can be no higher than seven inches (7") and no farther back than the front edge of the right-side headrest. It must taper to the deck at the back of the seat.
- e. If the interior is dropped at firewall/back of the hood, that portion of the firewall must be filled in vertically with aluminum. Interior may be dropped a maximum of two inches (2") from the top of the hood.
- f. Interior must be fastened flush at the top of the door and quarter panels and must taper gradually towards the center of the car at a maximum of seventy-degree (70°) angle from the deck.
- g. Interior must run in a straight line (vertical and horizontal) across the back of the car at the spoiler.
- h. All interiors must be made of aluminum.

#### K. Driver Compartment

- a. A full metal firewall fabricated from magnetic steel and/or aluminum must encompass the driver's compartment from front to rear, on both sides and floorboards.
- b. All cars must be equipped with a quick-release type steering wheel that is a full circle.
- c. Mirrors of any type will not be permitted.
- d. Radios and/or electronic and/or data communication devices will not be permitted.

- e. Any edge and/or sheet metal end in and around the driver compartment must be protected with trim and/or beading and rounded. Sharp and protruding edges will not be permitted.
- f. A rock guard with a minimum of three (3) additional roll bars must be mounted in front of the driver.
- g. Cockpit adjustable components with the exception of brake bias adjusters will not be permitted. Adjusters of any type, including but not limited to adjustable shocks, hydraulic or pneumatic weight jacks, trackers, ignition boxes, or similar adjustable components will not be permitted inside the cockpit of the car or within reach of the seated driver.

#### L. Body Skew

- a. The measurement of the left rear quarter panel from the center of the hub to the rear of the quarter panel cannot exceed fifty-four inches (54"). Measuring seventy-two inches (72") from the left rear quarter panel to the right rear quarter panel, then ninety-six inches (96") forward along the right side door, the diagonal measurement from that point to the top of the left rear quarter panel must be a minimum of one hundred seventeen inches (117").

### Section 9 – Brakes, Brake Components, and Wheel Hub

- A. Must be equipped with sufficient four (4) wheel braking system. On-track three (3) wheel braking is allowed.
- B. Brake calipers must be manufactured of aluminum.
- C. The brake caliper including brake caliper pistons must be used as produced by the brake caliper manufacturer.
- D. Brake rotors must be manufactured of magnetic or stainless steel.
- E. Brake rotors must be used as produced by the brake rotor manufacturer.
- F. Wheel hubs must be manufactured of aluminum or magnesium.
- G. Wheel hubs must be used as produced by the wheel hub manufacturer.
- H. The combined weight of the wheel hub, wheel bearings and seal, spindle nut and washers, brake rotor and attaching hardware, the axle cap, and the wheel spacer must not exceed twenty-seven (27) pounds.

### Section 10 – Suspension, Suspension Components, Springs, Shocks, and Steering

***Any and all new designs or modifications to an existing suspension and/or suspension component must be communicated to and approved by the Series Director before being used in competition.***

#### A. General

- a. Rear suspension designs and applications are constantly evolving. Although the intent of the rear suspension rules is an attempt to accommodate the majority of suspension and suspension component designs and applications currently being used in competition, the rules cannot be absolute.
- b. Rear suspension must utilize either coil or leaf springs.
- c. Rear suspension configuration used on current and new chassis(s) must be the design commonly known as four (4) link. Older cars currently competing with other rear suspension designs will be allowed to compete until further notification at the discretion of the Series Director.
- d. Swing arm and/or Z-Link suspension types are permitted. The shock on a swing arm or z-link rear suspension may mount to the bird cage or bottom radius rod. Top and bottom solid links must be mounted on heims and run in the opposite direction of the bird cage.
- e. Bump sticks are not allowed anywhere on the car.

#### B. Front Suspension

- a. All cars must utilize independent front coil spring suspension consisting of one (1) right and one (1) left lower control arm, one (1) right and one (1) left upper control arm, one (1) right and one (1) left spindle, one (1) right and one (1) left shock, and one (1) right and one (1) left spring / spring stack.
  - i. Lower control arms must be fabricated using magnetic mild steel or 4130 chrome moly tubing.
  - ii. Lower control arms may be of the "A" frame design with two (2) inner pivots or the Ford design with one (1) inner pivot and a strut rod to secure the control arm fore and aft movement. The strut rod may be mounted either forward or rearward of the control arm.
  - iii. All lower control arm frame mounts must be welded to the applicable frame rail. (The right lower control arm mounts must be welded to the right-side frame rail and the left lower control

- arm mounts must be welded to the left side frame rail.) This procedure applies to the Ford style including the strut rod as well.
- iv. Lower control arm mounts (inner pivot points) must remain to the outside of the front frame centerline for the respective side.
  - v. The frame mounts for the lower control arm inner pivots may be adjustable by two (2) methods:
    - 1. A series of single round holes.
    - 2. A machined slot that will accept a steel "slug" with a single round mounting hole.
  - vi. Both methods of mounting must produce a secure non-moveable mount when assembled and tightened.
  - vii. Upper control arms must be fabricated using magnetic mild steel or 4130 chrome moly tubing.
  - viii. Upper control arms may be either the "A" frame type design with or without a shaft or the individual tube type with individual inner pivot mounts.
  - ix. All upper control arm frame mounts must be welded to the applicable frame rail. (The right upper control arm mounts must be welded to the right-side frame rail and the left upper control arm mounts must be welded to the left side frame rail.)
  - x. The frame mounts for the upper control arm inner pivots may be adjustable by optional methods including but not limited to:
    - 1. A series of single round holes.
    - 2. A machined slot that will accept a steel "slug" with a single round mounting hole.
    - 3. A machined slot with a capture eccentric (cam) type adjuster.
  - xi. All methods of mounting must produce a secure non-moveable mount when assembled and tightened.
  - xii. Spindles must be fabricated or forged using magnetic mild steel.
  - xiii. If separate, spindle steering arms must be welded to the spindle.
  - xiv. Steering arms must remain below the spindle pin.
  - xv. Spindles must connect to the upper and the lower control arms by utilizing ball joints, monoballs, or spherical rod ends.

#### C. Rear Suspension Frame Mounts

- a. The frame/roll cage structure must have integral welded mounting brackets for the attachment of rear suspension components. Frame suspension mounts may be welded or bolted securely (without any movement) to the frame/roll cage structure.
- b. The only materials used to fabricate frame suspension mounts that will be permitted are magnetic steel or aluminum.
- c. Frame suspension mounts must be double shear configuration for mounting suspension components. Shear mounts must use minimum five-eighths of an inch (5/8") rod ends with minimum one-half inch (1/2") grade eight (8) bolts only. The bolt must be bolted through both shear mounts.
- d. Double shear frame suspension mounts must be a minimum of three-sixteenths of an inch (3/16") thickness on both sides of the mount. Double shear mount must be no wider than four inches (4") with a minimum one-half inch (1/2") grade eight (8) bolt with steel or aluminum spacers only.
- e. All frame suspension mount component mounting holes must be round and sized correctly for the fastener being used. Clearance between the fastener and the mounting hole must not exceed the next fractional drill size. Example: one-half inch (1/2") fastener, thirty-three sixty-fourths of an inch (33/64") mounting hole.

#### D. Axle Housing Mounts

- a. Only one (1) axle-housing mount per side will be permitted.
- b. The only materials used to fabricate axle housing mounts (birdcages) that will be permitted is aluminum or magnetic mild steel. Axle housing mounts fabricated of exotic heavy materials will not be permitted.
- c. When fabricating axle housing mounts, detail must be paid to functionality. The completed axle housing mounts, when comparing the right and the left side, must be as similar in design as possible.
- d. Axle housing mounts may be a solid (welded) type or a floating type (birdcage) design.
- e. The final assembled axle-housing mount must be a one (1)-piece mount. When a floating type mount (birdcage) is fabricated using two (2) pieces, the two (2) pieces must create a common one (1)-piece pivot (barrel). The two (2) pieces must be fastened or welded together to prevent independent movement of the two (2) pieces. The axle-housing mount must attach directly to the axle tube with clearance only to permit

rotation of the entire mount. Fore, aft or vertical movement of the mount or the axle housing within the mount will not be permitted.

f. Mounts for suspension attaching (radius) rods must be an integral part of the axle-housing mount. The mounts may be either a single or double shear configuration. When using a single shear configuration, a minimum thickness of one-quarter of an inch (1/4") for magnetic steel or one-half inch (1/2") for aluminum is required. When using a double shear configuration, a minimum thickness of three-sixteenths of an inch (3/16") inch for magnetic steel or one-quarter of an inch (1/4") for aluminum is required. Dynamic movement of any mount other than a rotating and pivoting movement as a result of suspension travel will not be permitted.

g. Unless otherwise authorized by the Series Director, the mounting of any component(s) other than suspension attaching (radius) rods or shocks will not be permitted on the axle housing mounts.

#### E. Rear Suspension Attaching (Radius) Rods

a. A maximum of two (2) attaching (radius) rods per side will be permitted.

b. The only materials used to fabricate attaching (radius) rods that will be permitted are magnetic steel or aluminum.

c. Attaching (radius) rods may be solid or tubular material. The material may be round or hexagon in shape.

i. Earnhardt Technologies Group Lower 4-Link Rod, Billet Aluminum Part # ETG-1248.A.00-ASM, is permitted.

ii. Wehrs Machine & Racing Products Part # WEH-WM625BB is permitted.

d. Spherical rod ends, or steel clevises must be used at the end of each rod for pivoting, static length adjustment, and mounting. Bushings of any type will not be permitted.

e. The final assembled attaching (radius) rod must not have the capability to change length dynamically by any means or devices.

f. Spherical rod end sizes may be a minimum of a five-eighths of an inch (5/8") rod end body with a one half inch (1/2") bearing to a maximum of a three-quarters of an inch (3/4") rod end body with a threequarters of an inch (3/4") bearing.

g. In all applications, the correct size fastener must be used when mounting the spherical rod end to a bracket (example: one-half inch (1/2") fastener must be used with a one-half inch (1/2") bearing and mounting hole). Metal step spacers will be permitted to reduce the hole size of the spherical rod end bearing.

h. Attaching (radius) rods must mount directly to the frame suspension mount at the forward end and to the axle-housing mount at the rearward end.

i. All rear suspension fasteners must be magnetic steel with a minimum diameter of one-half inch (1/2"). The use of grade eight (8) fasteners is highly recommended. All fasteners must be correctly sized for the component and application of use.

j. When rear suspension assembly is completed:

i. Attaching (radius) rods must be spaced on the frame a minimum of six inches (6").

ii. Attaching (radius) rods must be spaced on the birdcage a minimum of six inches (6") and a maximum of twelve inches (12").

iii. Measurements will be made from the center of each attaching (radius) rod bolt.

k. All attaching (radius) rods must be straight with the exception of the left lower that can have a bend for axle housing mount clearance.

l. Radius rods must not exceed three pounds (3 lbs.), including all hardware.

#### F. Rear Travel Limiter (Droop Rule)

a. A vertical travel limiting chain must be installed on the left rear of the car from the left rear axle housing to the frame. The travel limiting chain must attach to a bearing type mount or a clamp mounted bracket with the chain mounted to the top (12 o'clock) of the left rear axle tube, between the birdcage and the edge of the left rear bell of the axle housing, and to the left rear frame directly above the chain mount on the rear axle. Travel limiting chains must be installed so that when taunt they are as close to vertical as possible. One (1) compliance device may be used. The compliance device must not be more than one inch (1") thick (without a load applied) and remain completely open and visible. Compliance devices can be rubber or any like material but must not be installed in any type of canister. Springs, spring-loaded, and/or pneumatic devices will not be permitted. No tapered, beveled, or roller skate type of compliance rubber will be permitted. Compliance devices must be solid material, same diameter top to bottom, not hollowed or drilled to soften the material.

- b. The travel limiting chain including the compliance rubber must be installed so that when the car is jacked up from the rear the chain assembly is tight (no slack). The travel limiting chain is subject to inspection at any time during the event at the discretion of the officials. **Cars will be jacked up on a weight clamp on the under-slung frame rail one inch (1") in front of the rear axle tube between the center of the rear axle and the Panhard bar mount.** The left rear under-slung rail must be located between the left rear birdcage and the edge of the left rear axle housing bell—**If a chassis is not of the under-slung design, then the car will be jacked up on the left rear frame rail closest to the Panhard bar mount.** Cars will be jacked up until a forty-thousandths of an inch (.040") shim will slide between the left rear tire and the ground. Once the car is jacked up as described a vertical measurement will be taken from the ground to the top trailing edge of the rear deck bar, six inches (6") inboard of the left rear quarter panel outer edge. The measurement must not exceed fifty-one inches (51"). **(Cars without a left rear underslung must not exceed fifty inches (50")). In 2027, all cars must have a left rear underslung.**
- c. **Cars will need a weight clamp on the under-slung frame rail one inch (1") in front of the rear axle tube at ride height for tech officials to check droop.**
- d. All droop limiter assemblies must support the unsprung mass of the rear-end. The stretched value of the droop limiter assembly may be no more than three-quarters of an inch (3/4") at 1,200 lbs. The procedure: preload 100 lbs. zero (0) distance, pull to a value of 1,200 lbs.

#### G. Torque Control Devices

- a. Lift arm assemblies and pull bars will be permitted.
- b. Only one (1) torque control device may be used.
- c. Lift arms must attach to the axle housing using a mounting configuration that prevents any movement between the lift arm and the rear axle housing. A gusset or brace bar to prohibit side-to-side flex will be permitted.
- d. The forward end of the lift arm may use a spring over shock assembly (fifth coil), a spring or bushing, and a limiting chain.
- e. Pull bars may be adjustable on both ends; however, the adjustments must remain fixed during competition. Adjustors within reach of the driver will not be permitted. No hydraulic or pneumatic pull bars will be permitted.

#### H. Springs

- a. The front suspension must use magnetic steel coil springs
- b. The rear suspension may use coil or leaf springs. The coil springs must be magnetic steel. Leaf springs may be either magnetic steel or a composite material.
- c. Coil springs may be used individually or stacked.

#### I. Shock Absorbers

- a. Shocks are intended to dampen and help control spring frequencies in both the compression and rebound motions. The amount of force applied to move the shock piston and shaft assembly may be varied with the option of shock "builds" however the piston and shaft assembly must have the ability to move in both directions.
- b. Mono-tube, single-piston, nitrogen gas-charged shocks will be permitted. All shocks must utilize mechanical oil controls, such as spring shim(s), drum and disc(s), check ball and spring, needle, and seat for internal and external shock adjustments. Magnetic and/or electro-magnetic controls are not permitted. Remote nitrogen gas reservoirs will be permitted. The remote reservoirs may contain a compression adjuster. The adjustments described above are the only shock adjustments that will be permitted.
- c. Shock adjustments while the vehicle is in motion will not be permitted.
- d. Shocks and shock components may only be manufactured from steel or aluminum.
- e. Rotating parts will not be permitted inside or mounted to the shock absorber. Inertia/gyro-style shocks are not permitted.
- f. Thru-rod shocks will not be permitted.
  - i. Shock shaft can't exit both sides of the oil volume.
  - ii. Any shock with the dampening piston mounted more than one and one half (1.5) inches beyond the end of shock shaft, allowing the shaft to pass thru the main body on both ends simultaneously, will be classified as thru-rod or thru-shaft shock.
- g. Unless otherwise authorized, all shocks must be mounted as close to vertical as possible.
- h. Approved shock locations are as follows:

- i. One (1) shock will be permitted at each front wheel.
- ii. One (1) shock will be permitted at the right rear wheel.
- iii. Two (2) shocks will be permitted at the left rear wheel. When using only one (1) shock at the left rear wheel, the shock must be mounted behind the rear axle tube. When two (2) shocks are used at the left rear wheel, one (1) shock must be mounted behind the rear axle tube and the second shock must be mounted on top of or forward of the rear axle tube.
- iv. One (1) shock will be permitted mid-ship at the front of the lift arm assembly.
- v. One (1) braking shock will be permitted. The shock must be mounted within three inches (3") of the centerline of the rear axle center section. This shock must be mounted horizontally.
- i. Prior to introduction into competition a new design shock absorber must be submitted to the Series Director for approval. Shock absorber manufacturers may be required to provide a board of components for inspection and display.
- j. Air shocks are permitted.
- k. The maximum shock body outside diameter is two and one-half inches (2-1/2").
- l. The maximum front shocks length is twenty-one inches (21"), measured center to center of the shock eyes.
- m. The maximum rear shocks length is twenty-seven inches (27"), measured center to center of the shock eyes.
- n. No electrically adjusted or active dampers are allowed.
  - i. No electrical wires, transmitting, or receiving components will be allowed to be attached internally or externally to the dampers or mounted inside any component or dampers.
  - ii. No portion of the car including but not limited to – shocks and spring components or chassis components – may have the ability to communicate, transfer, transmit, receive any type of digital or analog data or any language and/or adjust or monitor in any way whatsoever including but not limited to a variation of a wireless remote device, phone, computer, tablet, or a mechanical remote device.
- o. Suspension covers are not allowed. Rear covers on the car are not allowed outside of your pit area. Spring and/or shock covers are permitted but must be fastened directly to the spring or shock.

## Section 11 – Steering Components, Wheels, and Tires

### A. Steering Components

- a. Only one power steering pump allowed. Electronic steering and/or electronic steering components will not be permitted.

### B. Wheels

- a. Only aluminum wheels will be permitted for competition.
- b. The wheels must be mounted to the hubs utilizing lug nuts. "Knock off" and/or single type wheel mounting systems will not be permitted.
- c. Only wheels that are 14-inches wide will be permitted. Using a wheel that is bigger and/or smaller than 14-inches wide will not be permitted.
- d. The combined weight of the wheel, wheel hardware, wheel disc and fasteners, and tire must not exceed 40 lbs.
- e. The maximum front track width will be ninety inches (90") and the maximum rear track width will be eighty-eight inches (88"), measured from the outside edge of the tire to the outside edge of the tire.
- f. Only approved wheel discs will be permitted. Approved wheel discs are wheel discs that are fastened to the wheel using a minimum of three (3), one-quarter inch (1/4") or five-sixteenths of an inch (5/16") diameter hex head bolts. The use of wheel discs with any other type of fastener will not be permitted.
- g. Only aluminum wheel spacers will be permitted.
- h. Wheel/air bleeders are not permitted.
- i. Titanium Lug Nuts and Bead Lock Bolts are permitted.
- j. Wheel weights are not permitted.
- k. Left Rear Mud guards/covers, regardless of weight must be approved by series Technical Director and/or Series Director.
  - i. Mud guard/cover and all components, including but not limited to (guard/cover, bracket, bolts), must not exceed ten pounds (10 lbs.) and one-quarter inch (1/4") thickness.
  - ii. Mud guard/cover must be designed to slide over axle tube and be fastened with two (2)

one-half inch (1/2") bolts Grade 5 or higher.

iii. The only materials used to fabricate mud guard/cover that will be permitted is aluminum or magnetic mild steel. Mud guard/cover fabricated of exotic heavy materials will not be permitted.

### C. Tires

- a. Left Front ONLY – 90 Hoosier Tire NLMT 3; LM30; W-30; WRS2-55; may be siped or grooved.
- b. Right Front, Left Rear, tire NLMT 3, LM30 or W-30. 90s on fronts and left rear only.
- c. Right Rear Hoosier tire NLMT 3-92 or WRS2-55-92 on right rear only.
  - i. Does not have to be the same compound markings on all 4 corners.
- d. WRS2-55 Option, RF, LR, RR, - 88,90,92 can be siped.
  - i. No grooving may be used on all RF, LR, RR corners.
- e. There may be races that a 92 - NLMT 4 will be noted as an option on the right rear for the feature only.
  - i. This will be announced prior to race week.
- f. The above options will be allowed to groove the factory pre-molded cross hatch marks only.
  - i. #2 grooving head and blade to replicate the original cross groove.
  - ii. The new groove is not to exceed the depth of the factory circumference groove. No siping.
- g. NO extra grooving, siping, or needling or altering beyond 24 grit sandpaper in removing the glaze will be allowed on a tire except where specified in the tire rules above.
  - i. **Warmers for artificially warming are prohibited.** The tech directors will be the final decision if the tire is allowed to run.
- h. Recommended washing tire with water only.
  - i. Warning soaps and cleaning products including **Mud off products** may be detected as chemicals or altering the tires, are subject to disqualification, fines, and/or suspension.
- i. You may only use sandpaper up to and including 24 grit to remove the glaze on the top layer of tires.
  - i. When you are completed with the sanding of the tires, the edges of the tread block must remain the same as the edge of the block next to it. You will only be able to create the look of a worn tire and not something of a different tire face appearance (example: no wavy tread pattern or deep grinding will be allowed).
  - ii. Metal grinding disks are not permitted.
- i. Durometer reading should be no less than 52 hardness.
  - i. First offense:
    - a. Fail durometer inspection for time trials and you will start tail end of an assigned Heat Race.
    - b. Fail post-heat race durometer inspection and you will start tail end of an assigned B-Feature event.
    - c. Fail post-race B-Feature or A-Feature inspection, ~~driver and car will be scored as last place for the night and receive points for last place, no money will be paid for event.~~ **Tire is subject to being sampled and tested at Blue Ridge Labs. Winnings will be held until the tire sample has been returned to the SLMR Series.**
  - ii. Second offense:
    - a. \$1,000.00 Fine, up to 300 points deducted from championship points, no tow money will be paid.
    - b. Violator(s) will assume all costs included in any testing procedures.
- j. Tire testing protocol
  - i. **Two (2)** tire samples will be taken from the same tire. More than one tire may be cut for samples.
  - ii. Tire samples will be cut no smaller than 1/4 inch wide and 2-3 inches strips with 4 or bigger blade from tire. Cuts will be made by team member (driver, pit crew, or owner).
  - iii. SLMR officials WILL NOT cut tire sample.
  - iv. Each tire sample will be marked by date, tire sample i.e. left rear (LR), and signed by representative of team.
  - v. Each tire sample will be put in a separate jar, placed in separate sealed evidence bag, and taken into custody by SLMR representative.
  - vi. Tire sample will be sent to at cost of SLMR to;

Blue Ridge Laboratories  
660 Merrimon Ave Suite E  
Asheville, NC 28804

vii. The other **one (1) tire sample** will be held in sealed evidence bags at the SLMR office located in Omaha, NE.

viii. If tire sample comes back in what would be deemed illegal;

a. **First offense- \$1,000 fine, loss of winnings for the event. loss of 60 championship points including any points earned for event such as contingency awarded points, and next three events will start no better than seventh (7<sup>th</sup>) in the A feature. In the event there is not three events competed in the season; it will carry into the next season.**

b. **Second offense- \$2,000 fine, loss of winnings for the event, loss of 120 championship points including any points earned for the event such as contingency awarded points, and will also lose contingency points for the next three events. Next five events will start no better than seventh (7<sup>th</sup>) in the A feature. In the event there is not five events competed in the season; it will carry into the next season.**

k. Dispute of tire findings

i. Driver will be notified by SLMR representative of Blue Ridge Lab findings via phone call, text, and/or email.

ii. Driver has 72 hours from notification of lab findings to decide if he/she wants to protest Blue Ridge Lab findings. Driver will notify SLMR representative via phone, text, and/or email of decision to protest.

ii. Team can request second tire sample to be sent;

a. Team will need approval by SLMR Rule Enforcing Committee.

b. Team will incur cost of shipping and lab fees of \$250 testing second tire sample.

iii. If second tire sample comes back in what would be deemed illegal. Driver will be notified of lab findings by SLMR representative.

a. Penalties listed in J-VII-a,b will be enforced at time of notification.

l. Tire protest: Any driver, owner, or crew chief competing in the A feature event (must take a lap) are eligible to protest tires for chemical compounds or conditioning.

i. Cars being protested must have finished in the top 5 A feature positions.

ii. Protest fee will be \$300 for 1 tire – 1 test. All other tires on the same car can be tested for an additional \$250 per tire on the same night. Totaling \$1050 for all 4 tires on the same car being protested at the same event.

iii. Protest must be cash/bills must be in denomination of not less than \$20.

m. Tire protest and money must be presented within 15 minutes of the drop of the checkered flag to a SLMR tech official or SLMR Director.

i. Any winnings of the Driver of the protested tire will be held until test comes back.

n. Tire Sample(s) will be cut no smaller than ¾ inch with a 4 blade or bigger blade/tool provided by the person being protested.

**o. Refusal of tire protest will carry the same penalties as C-j-viii, which is due before competing at a SLMR series event.**

i. Protester will receive his/her money back if protest is denied.

**p. If testing proves tire sample to be illegal, will carry the same penalties as C-j-viii, which is due before competing at a SLMR series event.**

i. If protested tire comes back to be illegal the person who protested the tire(s) will receive the protested driver's winnings for that event up to the amount that was used to protest.

q. The maximum size for any tire in competition is eleven inches (11") x twenty-nine inches (29") x fifteen inches (15"), unless otherwise specified and made known to all competitors.

r. The maximum outside circumference of the tire will be ninety-three inches (93"), unless otherwise specified and made known to all competitors.

s. The maximum width of the tires measured from the outside edge(s) of the sidewalls across the face of the tire will be sixteen and three-quarters of an inch (16-3/4"). There will be a tire hoop used for inspection and the tire must pass through the tire hoop freely, without any manipulation or outside contact.

- t. The tire rule for any event may be amended from time to time and will be made known to all competitors.
- u. Chemical alterations, vulcanizing, tire softening, defacing, and/or altering the face of the tire lettering and/or tire stamping will not be permitted. Chemicals or tire softening is not permitted at any time.

## Section 12 – Safety Equipment

### A. Seat Belts and Restraint Systems

- a. All cars are required to have an SFI 16.1, 16.2. or 16.5 approved restraint system.
- b. They must be of the approved racing type with quick release aircraft type hookups.
- c. NO stock type seat belts allowed.
- d. Belts must be no older than 3 years on the production date.
- e. All cars must have seat belts and shoulder harness securely fastened to the frame or roll bar.
- f. In any type of manufacturer's installation, the fasteners must be as supplied by the manufacturer.
- g. Seat belt material should not come in contact with any sharp or metal edge, including when the material passes through the seat.

### B. Seats

- a. All current seats must be full containment type constructed of aluminum or approved carbon fiber and **must adhere to the general design specifications of SFI 39.2 seat construction standards**. Design should include comprehensive head surround, shoulder and torso support system, energy impact foam, and removable head foam.
- b. **Carbon fiber seats must have a current valid SFI 39.2 certification.**
- c. Seats must be used as supplied and installed following instructions provided by the seat manufacturer.
- d. Seats must be mounted to a seat frame that is welded to the car frame/roll cage structure. Attaching points, angles, and materials for the seat frame and mounting of the seat to the seat frame must be in accordance to the seat manufacturer's instructions.
- e. Seat mounting brackets must use properly sized bolts and washers for the hole in the bracket. No oversized holes or slotted holes in the brackets.

### C. Fire Suppression

- a. All cars shall be equipped with a thermally deployed automatic fire suppression system. The fire suppression system will consist of a DOT-approved cylinder manufactured from aluminum or steel with a capacity of 10 lbs. of fire extinguishing agent, steel or steel reinforced lines, and has a minimum of two (2) thermally activated discharge nozzles.
- b. All systems must meet or exceed SFI 17.1 specifications.
- c. Systems must be fully charged with 10 lbs. of DuPont FE-36, 3M NOVEC 1230, FireBull, or 4Fire and display a legible and valid SFI and manufacturer label depicting fire extinguishing agent, capacity, and certification date. Cylinders that are beyond useful certification date must be inspected, serviced, and re-labeled by the manufacturer.
- d. Cylinders must be mounted forward of the fuel cell. Cylinders must be securely mounted to the frame/roll cage assembly. The certification label must be unobstructed and easily accessible for inspection when the mounting is complete.
- e. Two (2) thermally activated nozzles must be used. One (1) nozzle must be located directly above the fuel cell in the fuel cell area and the second nozzle located in the driver cockpit area. An optional engine bay nozzle may be added.
- f. An optional manual override cable may be added.
- g. **A fire extinguisher, in working order and up to date, must be recertified three (3) years from production date, will be required in your race car. (Recommended when purchasing a new fire extinguisher to purchase the 10-pound fire bottle or safe craft suppression system with the thermal hoses running to the driver's cock pit and one to the fuel cell.)**

### D. Window Nets

- a. All cars are recommended to use arm restraints or a window net, 16x20 rectangular shape mesh or ribbon style, must be mounted in accordance with the manufacturer's instructions and technical director's satisfaction, must latch at the top.
- b. Window net will not be required but recommended when using a full containment seat and a HANS (or similar)

device.

c. Arm restraints highly recommended.

#### E. Miscellaneous Safety

a. Raceceivers are mandatory, channel 454.000 (unless otherwise stated at drivers' meeting.)

b. All drivers must wear a full-face helmet with a helmet certified to Snell SA2015/FIA-8859-2015, Snell SA2020/FIA-8860-2018, SFI 31.1/2015 or SFI 31.1/2020 is required to be always worn during competition or on the racing surface.

c. All drivers will be required to wear a fire-resistant driving uniform meeting the minimum of the SFI 3.2A/5 specifications and display a valid SFI 3.2A/5 label on the outside of the uniform.

d. Head and neck restraint devices are recommended such as a HANS or similar. A minimum of a full wrap around neck brace is required.

e. Fire suits of at least a fire-retardant material are mandatory. (SFI 5 is the recommended minimum.)

i. Sleeves must be rolled down.

ii. Recommended drivers must wear gloves at all times they are on the track. Driver's gloves should meet or exceed the SFI 3.3 specification and have a legible and valid SFI 3.3 label.

iii. Nomex underwear is highly recommended, including hood and socks.

iv. Recommended drivers should wear shoes that meet the minimum of the SFI 3.3 specifications and display a valid SFI 3.3 label. No tennis shoes allowed.

f. All roll bars within the driver's area are recommended to be padded with flame retardant foam roll bar padding

g. Solid thumb saver steering wheels are highly recommended

h. Window bars in the windshield area will be required from left 1 ½ inch down tubes to right 1 ½ inch down tubes connecting roof hoop to the cowl area there must be ½ inch tubes (vertically mounted) spread a maximum of 6 inches.

i. Window Screen are recommended across the full area from left 1 ½ inch down tube to right 1 ½ inch down tubes, no bigger than 1x1 squares and no smaller than ½ x ½ squares across the whole front area.

#### F. Series Safety Requirements

ALL CARS ARE ELIGIBLE TO RUN IN 2026. General safety rules SECTION 12 A. through E. All cars not running safety rules F a through f. (See below) \$50 will be deducted from each advertised position in the feature, no driver will receive less than \$100 start money. Series members will still be able to receive their 2 provisional and contingency awards (including Hoosier Hard Charger).

a. All current seats must be full containment type constructed of aluminum or approved carbon fiber and must adhere to the general design specifications of SFI 39.2 seat construction standards, does not need to be certified. Design should include comprehensive head surround, shoulder and torso support system, energy impact foam, and removable head foam.

b. Head and neck restraint devices such as a HANS or similar are required.

c. Window bars in the windshield area will be required from left 1 ½ inch down tubes to right 1 ½ inch down tubes connecting roof hoop to the cowl area there must be ½ inch tubes (vertically mounted) spread a maximum of 6 inches.

d. Window screen across the full area from left 1 ½ inch down tube to right 1 ½ inch down tubes, must be 24 inches wide by 12 inches tall (it is acceptable to have a cutout for a steering buddy 4 inches wide by 2 inches tall). no bigger than 1x1 squares and no smaller than ½ x ½ squares

e. 10-pound Fire Bottle or Safe craft suppression system with the thermal hoses running to the driver's cock pit and one to the fuel cell will be required. The gauge must be able to be easily read from under the car during inspection, bottle must have 75% to full capacity to be considered legal. Must service every three years.

f. Driver door intrusion plate

### Section 13 – Electronics, Gauges, and Dash Modules

A. Two-way communication devices in and/or attached to the race vehicle or on the driver's person will not be permitted.

B. Cellular, satellite, and wi-fi, devices in and/or attached to the race vehicle or on the driver's person will not be permitted (Including cell phones and/or smart watches).

C. Antennas will not be permitted in and/or attached to the race vehicle or carried by the driver.

D. All forms of a vehicle position systems will not be permitted (GPS).

E. Only approved lap timing and or lap time recording devices (transponders) will be permitted.

F. Gauges to monitor engine conditions are permitted but will be limited to the following;

- a. Oil Pressure
- b. Oil Temperature
- c. Engine Coolant Pressure
- d. Engine Coolant Temperature
- e. Fuel Pressure
- f. Battery Voltage
- g. Engine RPM

G. All electronic gauges whether analog or digital, except tachometers, will only be permitted to have one (1) input from the respective gauge sensor. Output from the gauges will not be permitted. Tachometers will be permitted to record engine RPM for recall and playback.

H. When an electronic dash module is used in lieu of individual gages, only the inputs as described above for individual gauges will be permitted. All other input channels must be disabled and blocked off from usage. Only engine RPM may be recorded. Wiring to the electronic dash module must be accessible and removable for ease of inspection.

I. All additional wiring harnesses related to electronic dash modules or any other type of data acquisition must be completely removed from the race vehicle during an event.

#### **Section 14 – Miscellaneous**

A. Full or partial car covers will be permitted only when there is inclement weather.

B. It is recommended that all teams have a fire extinguisher in the rear of their transporter. The fire extinguisher is recommended to be a minimum of 2.5 gallons A-FFF type or 20 lbs. Purple-K.

C. No cameras and/or video recorders and/or photographic recording equipment may be mounted below the deck of the car.

D. No driver controlled electronic devices, computer-controlled devices, or cellular devices are permitted in the cockpit while on track.

E. No data systems or data collection harnesses are permitted

F. Signaling sticks are permitted (2) Two inch (2)" maximum diameter with a length of thirty inches (30") are allowed to signal from a safe area where pit pass access is required. No signaling from the general admission area unless otherwise instructed at a drivers meeting. Only tape is permitted on a signaling stick. No lighted or flashing signaling sticks are permitted.

#### **Section 15 – Drawings (Provided by the World of Outlaws Late Models)**



# 2024 LATE MODEL BODY DIMENSIONS MASTER SIDE VIEW

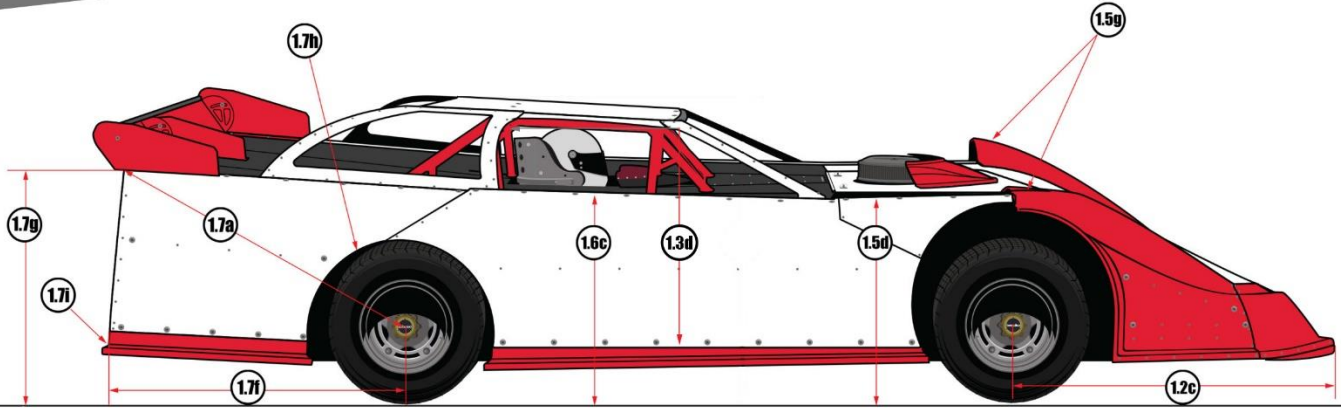

- 1.2c** Stock nosepiece can extend a maximum of fifty-three inches (53") from center of front hub to farthest point extending forward
- 1.3d** Minimum thirty eight inches (38") from bottom of roll cage to top of the floor pan
- 1.5d** Front fenders cannot exceed thirty-seven inches (37") in height measured from the ground
- 1.5g** The front fender flares may not be higher than fenders by more than four inches (4")
- 1.6c** Doors cannot exceed thirty-seven inches (37") in height measured from the ground
- 1.7a** Fifty-four inches (54") MAXIMUM center of rear hub to top corner of quarter panel
- 1.7f** Forty-nine inches (49") MAXIMUM length from center of rear hub to end of quarter panel
- 1.7g** Thirty-nine inches (39") MAXIMUM height from top of deck to ground
- 1.7h** MINIMUM of two inches (2") tire clearance from body
- 1.7i** Skirting cannot extend beyond the quarter panel



# 2024 LATE MODEL BODY DIMENSIONS MASTER SIDE VIEW

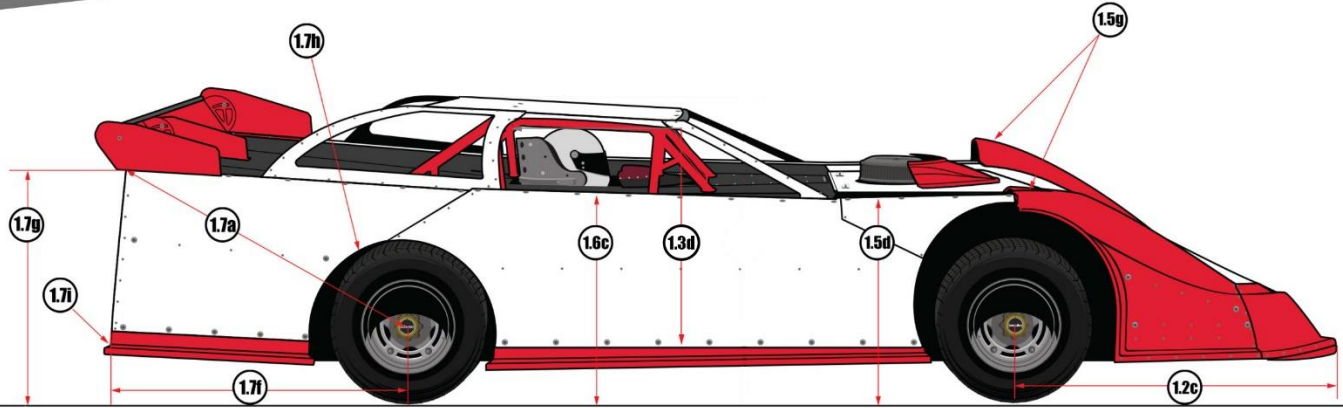

- 1.2c** Stock nosepiece can extend a maximum of fifty-three inches (53") from center of front hub to farthest point extending forward
- 1.3d** Minimum thirty eight inches (38") from bottom of roll cage to top of the floor pan
- 1.5d** Front fenders cannot exceed thirty-seven inches (37") in height measured from the ground
- 1.5g** The front fender flares may not be higher than fenders by more than four inches (4")
- 1.6c** Doors cannot exceed thirty-seven inches (37") in height measured from the ground
- 1.7a** Fifty-four inches (54") MAXIMUM center of rear hub to top corner of quarter panel
- 1.7f** Forty-nine inches (49") MAXIMUM length from center of rear hub to end of quarter panel
- 1.7g** Thirty-nine inches (39") MAXIMUM height from top of deck to ground
- 1.7h** MINIMUM of two inches (2") tire clearance from body
- 1.7i** Skirting cannot extend beyond the quarter panel



# 2024 LATE MODEL BODY DIMENSIONS QUARTER PANEL OPTIONS

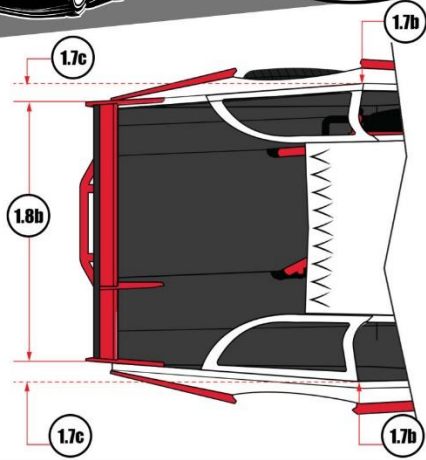

**OPTION 1**

Rear decks must taper from seventy-six inches (76"), as measured at the top over the rear hubs, uniformly back to seventy-two inches (72") at the spoiler, equally on both sides.

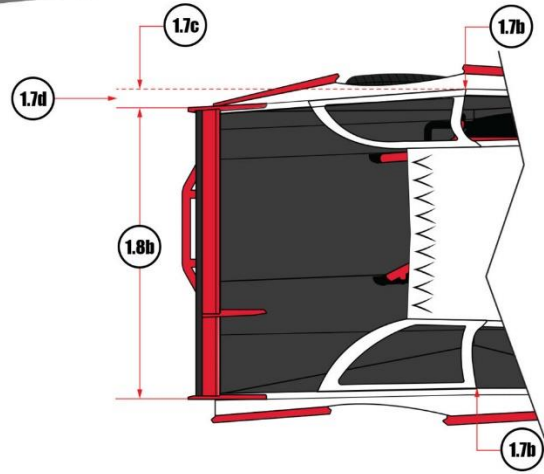

**OPTION 2**

Rear decks must taper from seventy-six inches (76"), as measured at the top over the rear hubs, uniformly back to seventy-two inches (72") at the spoiler, equally on both sides.



# 2024 LATE MODEL BODY DIMENSIONS

## SIDE VIEW SPECIFICATIONS

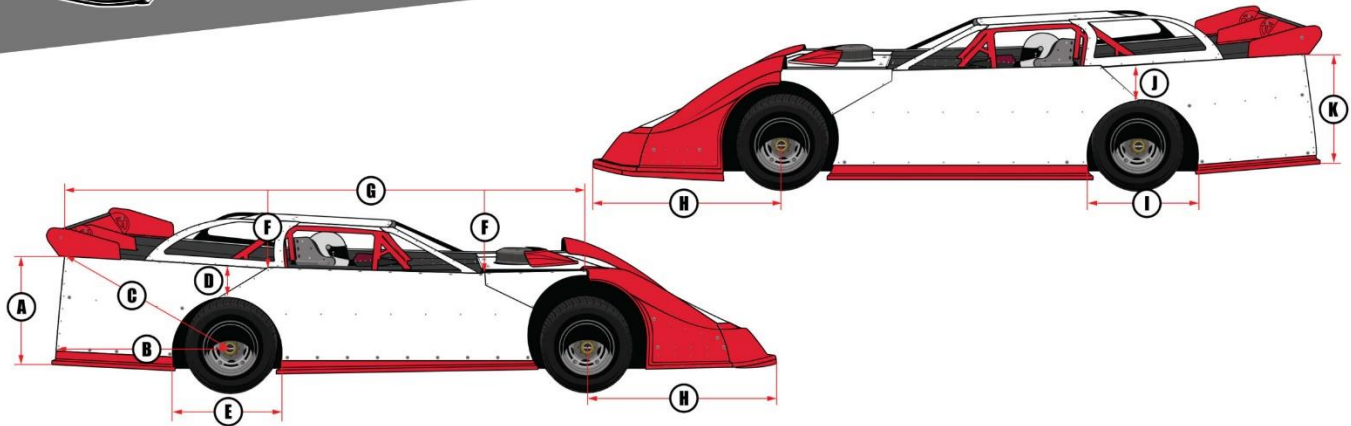

- A** Twenty-Seven inches (27") MINIMUM, Thirty-One Inches (31") MAXIMUM INCLUDING Plastic
- B** Forty-Nine Inches (49")
- C** Fifty-Four Inches (54")
- D** Eight Inches (8") MINIMUM
- E** Twenty-Nine Inches (29") MINIMUM, Thirty-Two Inches (32") MAXIMUM
- F** One Inch (1") Drop
- G** Two Inches (2") Drop at from rear of car to top of fender
- H** Fifty-Three Inches (53")
- I** Twenty-Eight Inches (28") MINIMUM, Thirty-Three Inches (33") MAXIMUM. Opening at sheet metal MUST be a symmetrical circle
- J** Ten Inches (10") MINIMUM
- K** Thirty-Three Inches (33") MINIMUM, Thirty-Six Inches (36") MAXIMUM INCLUDING Plastic



# 2024 LATE MODEL BODY DIMENSIONS SPOILER SUPPORTS

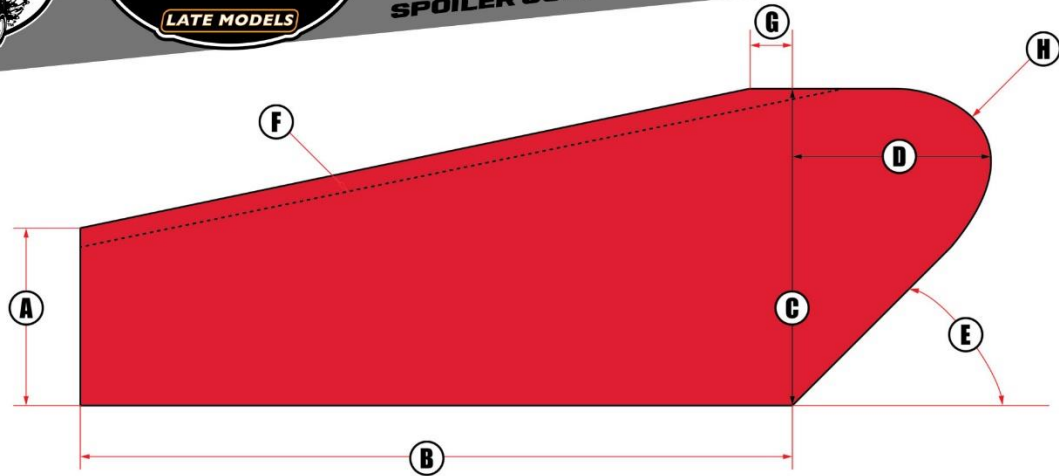

**A** Four and One Half Inches (4.5")

**B** Eighteen Inches (18")

**C** Eight Inches (8")

**D** Eight Inches (8")

**E** Forty-Five Degrees (45°) from mounting surface

**F** Broken line indicates one-half inch (1/2") MAXIMUM break

**G** One inch (1")

**H** Radius must be MINIMUM of two inches (2") at top rear

**NOTE** No more than three (3) spoiler supports permitted. Front edge of supports must be in line.

**NOTE** DIMENSIONS HAVE ZERO TOLERANCE!



# 2024 LATE MODEL BODY DIMENSIONS TOP VIEW

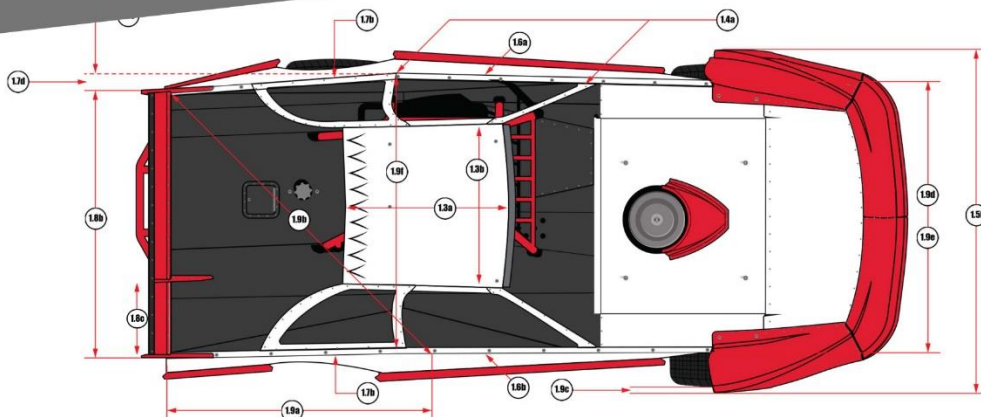

**1.3a** Roof length must be a minimum of forty-four inches (44") to a maximum of fifty-four inches (54")

**1.3b** Roof width must be a minimum of forty-eight inches (48") to a maximum of fifty-two inches (52")

**1.4a** All roof side panels must extend to edge of decking

**1.5f** Front fender flares cannot extend beyond front tire more than one-inch (1") in width with the wheels pointed straight

**1.6a** Door cannot exceed seventy-seven inches (77") in it's entirety at top of door

**1.6b** Door cannot exceed ninety inches (90") in width at the bottom in the center of the car

**1.7b** The quarter panels cannot exceed seventy-six inches (76") in width at any point behind the center of the rear hub as measured at the top

**1.7c** Rear decks must taper from seventy-six inches (76"), as measured at the top over the rear hubs, uniformly back to seventy-two inches (72") at the spoiler, equally on both sides

**1.7d** Four inches (4")

**1.8b** Maximum spoiler width is seventy-two inches (72")

**1.8c** Breakaway panel maximum of twenty one inches (21")

**1.9a** Reference point. Ninety-six inches (96") from rear deck bar

**1.9b** Diagonal reference point. One-hundred seventeen inches (117") from left-rear spoiler to 1.9a reference point

**1.9c** Outside of right-front fender to outermost point of right front tire

**1.9d** Total width of fenders at center of tires must be seventy-six inches (76")

**1.9e** Total with of the top of the body at the hack of the hood cannot exceed seventy-six inches (76")

**1.9f** Total width of the top of the body at the roof post cannot exceed seventy-six inches (76")